

CS5010

The Lab-Unit Cap Sealing Machine

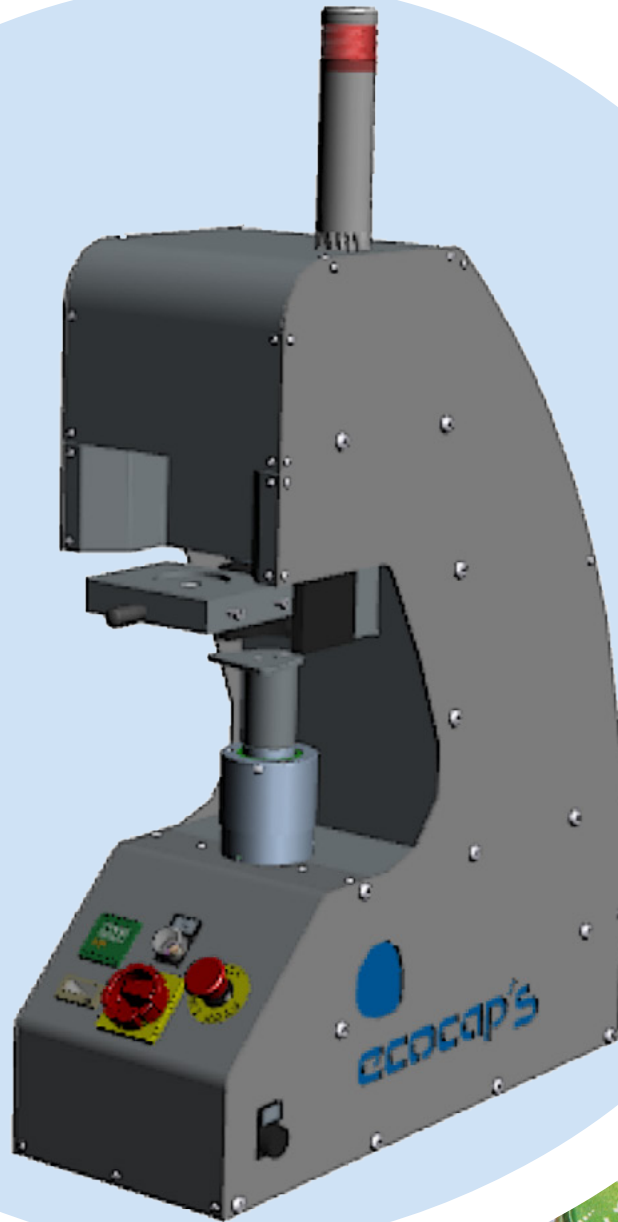

css010

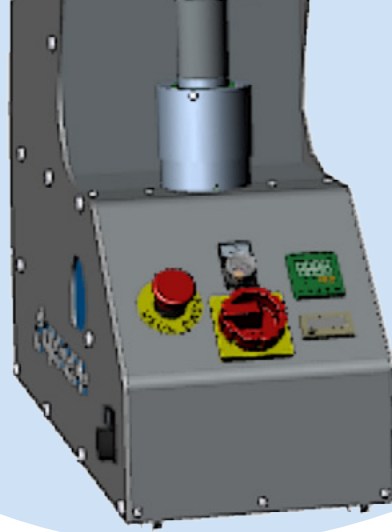

The Lab-Unit Cap Sealing Machine

Ecocap's unique and worldwide patented system to protect and stand out all your cans:

- Fits all can sizes
- Compatible with PakTech, Hi-Cone and other upstream/downstream solutions
- Ecocaps Lids 100% Customizable – 100% Recyclable

Developed for Test and Instant Production

- Semi-Automatic
- Easy-to-use
- Possible to connect to domestic power supply

Light & Compact

- Weight: 60 kg
- Dimensions (WxDxH): 250 x 665 x 950 mm

Full package solution

- On Site Training
- Scheduled Maintenance
- Ecocaps Lids Supply

Production Speed	LAB – UNIT
No. of sealing head	1
Max lids capacity	20
Installed power	1 KVA
Air Consumption	0 l/min
Net weight	60 kg

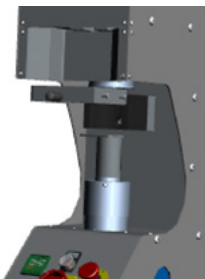
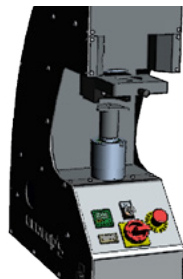
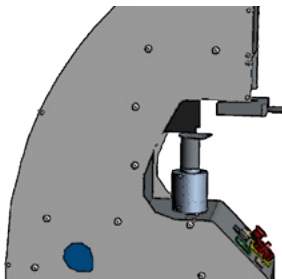

**MORE
HYGIENIC**



**NEW
MARKETING
TOOL**



**EXTRA
PROMOTION
SPACE**



**WATER
AND HEAT
RESISTANT**



**100%
RECYCLABLE**



**IDENTIFIES
THE CANS
FROM ABOVE**

ecocap's