

CSS010

Lab-Unit Cap
Sealing Machine

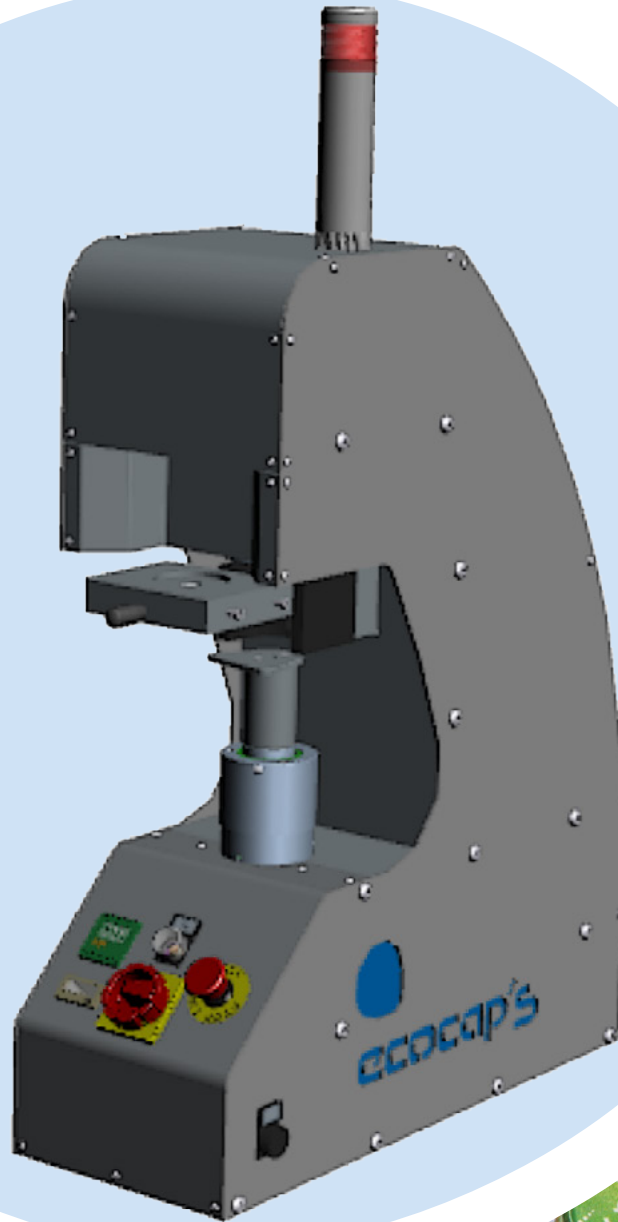

css010

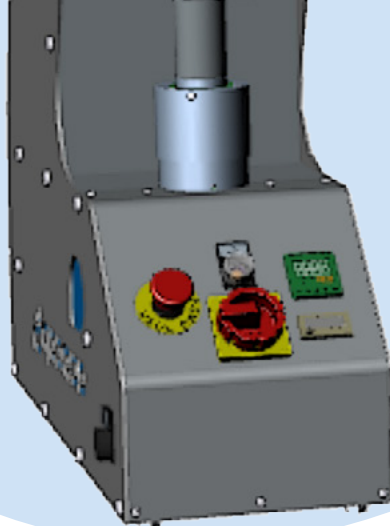

Lab-Unit Cap Sealing Machine

Ecocap's, il sistema unico e brevettato in tutto il mondo per proteggere e dare visibilità alle tue lattine:

Adatto per ogni tipo di lattina
Compatibile con PakTech, Hi-Cone e altre soluzioni di packaging
Utilizza capsule al 100% personalizzabili e 100% riciclabili

Macchina sviluppata per test ed eventi

Semi-Automatica
Facile da usare
Collegabile alla rete elettrica domestica

Leggera e compatta

Peso: 60kg
Dimensioni: (LxPxA): 250 x 665 x 950 mm

Soluzione completa

Training in loco
Manutenzioni programmate
Fornitura delle capsule Ecocaps

Velocità di produzione	Lab - Unit
N° teste saldanti	1
Capienza capsule	20
Potenza installata	1 KVA
Consumo d'aria	0 l/min
Peso Netto	60 kg

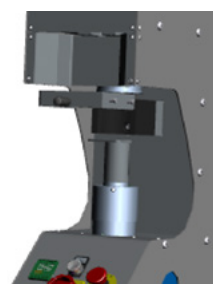
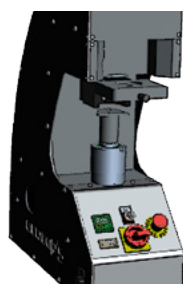
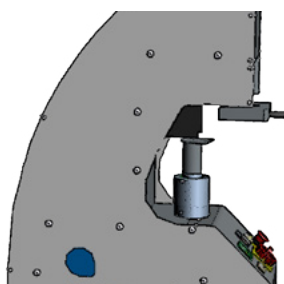

**PIÙ
IGIENE**



**NUOVO
TOOL
DI
MARKETING**



**SPAZIO
PER LE TUE
PROMOZIONI**



**RESISTE
ALL'ACQUA
E AL CALORE**



**100%
RECYCLABLE**



**IDENTIFICA
LE LATTINE
DALL'ALTO**

ecocap's