

CSS648

The Cap
Sealing Machine

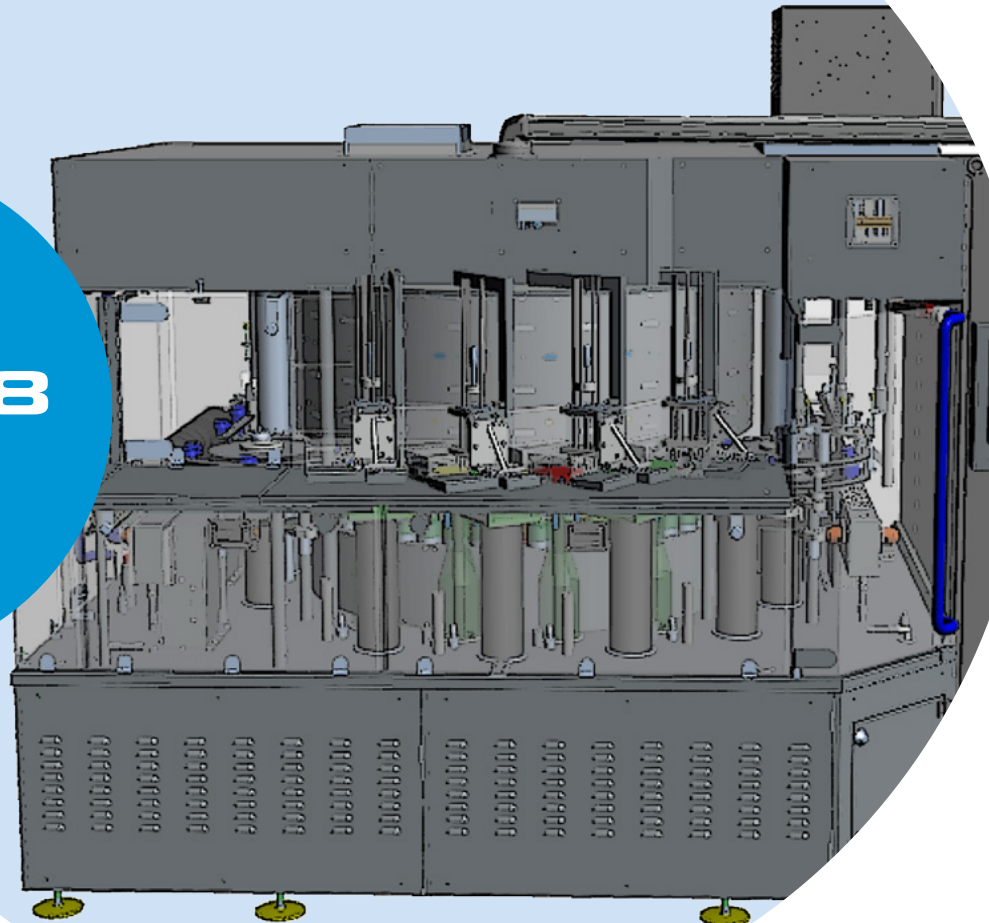

css648

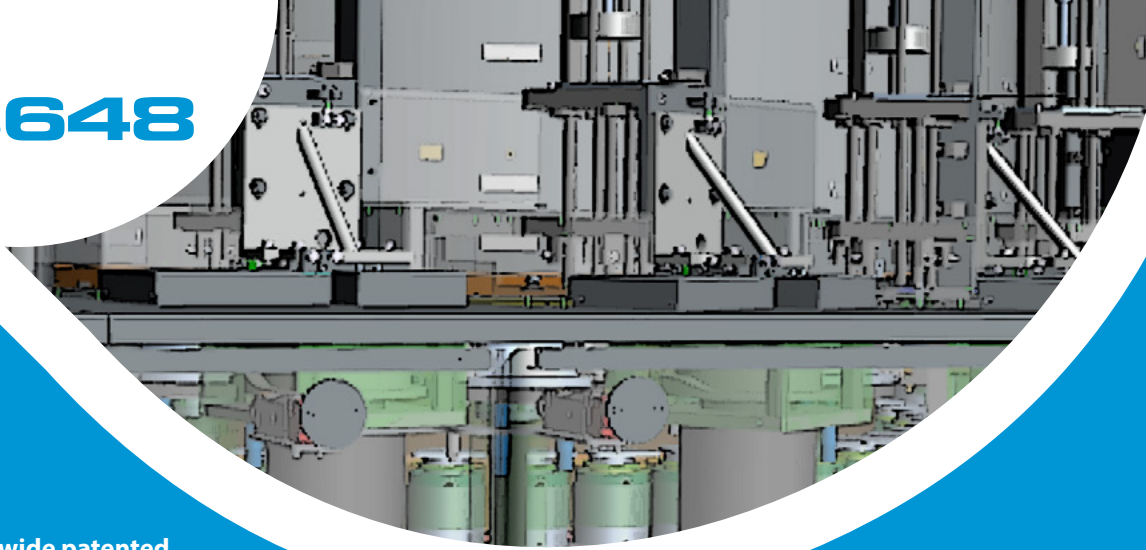

The Cap Sealing Machine

Ecocap's unique and worldwide patented system to protect and stand out all your cans:

- Fits all can sizes
- Compatible with PakTech, Hi-Cone and other upstream/downstream solutions
- Ecocaps Lids 100% Customizable, 100% Recyclable

Developed for all Production Line

- From 350 to 900 pcs/min
- "U-turn" or "Z" Layout

Hi-tech Concept

- 100% Servo-motor motion control
- User Friendly HMI

Full package solution

- On Site Training
- Scheduled Maintenance
- Ecocaps Lids Supply

Production Speed	55.000 pcs/hour
No. of sealing head	48
Max lids capacity	20.000
Installed power	28 KVA
Air Consumption	450 l/min
Net weight	9.500 kg

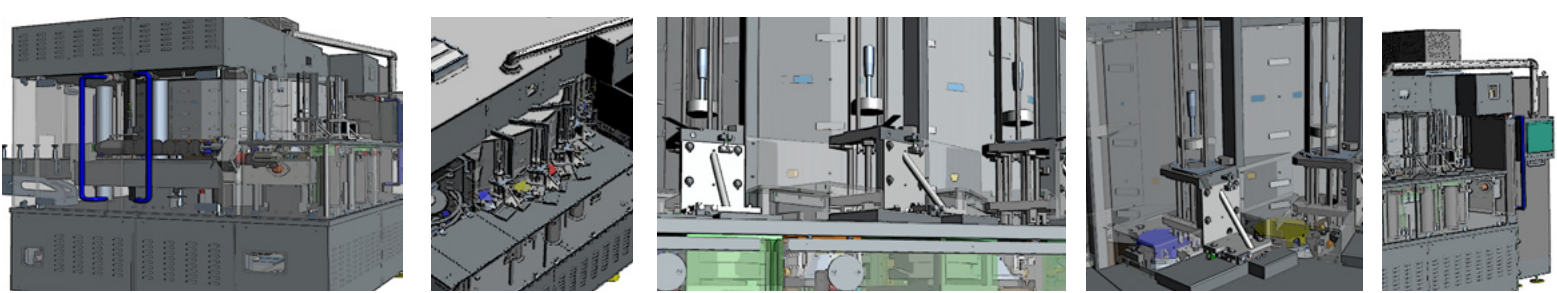

**MORE
HYGIENIC**



**NEW
MARKETING
TOOL**



**EXTRA
PROMOTION
SPACE**



**WATER
AND HEAT
RESISTANT**



**100%
RECYCLABLE**



**IDENTIFIES
THE CANS
FROM ABOVE**

